

Preliminary

Roland

Audio & Video Matrix Switchers featuring eight multi-format inputs and built-in scalers



XS SERIES

MULTI-FORMAT MATRIX SWITCHERS

XS-84H **4** OUT | XS-83H **3** OUT | XS-82H **2** OUT



Analog and digital audio and video converted and distributed to digital outputs



*iPad not included.



XS-84H
8 in x 4 out Matrix Switcher **4 OUT**

Product Overview

- Inputs: 8 HDMI and 8 RGB/Component/S-video/Composite analog video
- Outputs: 2,3, or 4 HDMI and 2,3, or 4 HDBaseT (*Switchable HDMI or HDBaseT per output)
- Support for maximum resolution of WUXGA and 1080p, with built-in scalers
- 8 stereo line inputs (2 mic compatible with 48V phantom) with built-in AD/DA conversion and embedded/de-embedded HDMI audio
- 16 channel digital audio mixer with audio digital effects (HPF, 4 Band EQ, noise gate/expander, and compressor) and outputs delay.
- Support for RS-232C, network, and iPad control

Integrating Many Functions into One Unit

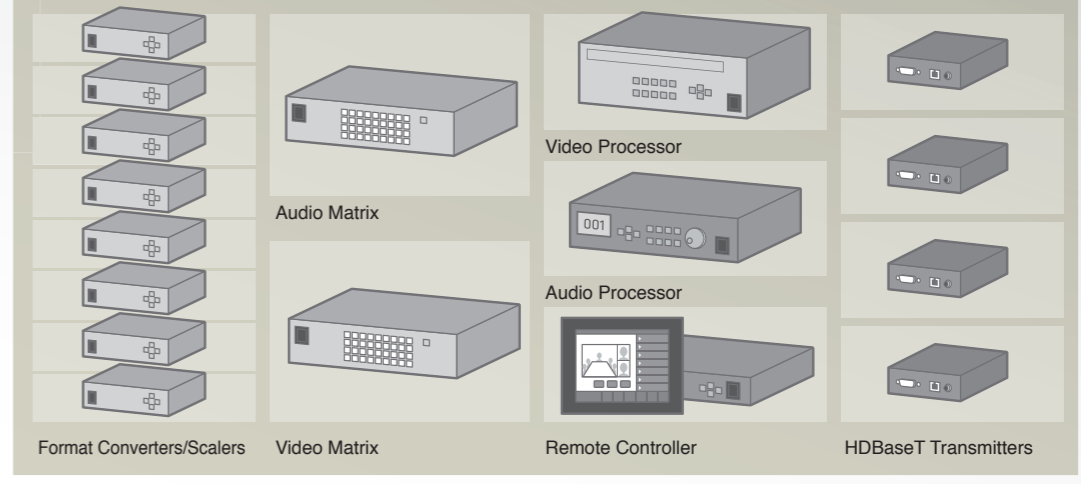

XS-83H
8 in x 3 out Matrix Switcher **3 OUT**



XS-82H
8 in x 4 out Matrix Switcher **2 OUT**

Integrated Video and Audio Environment

- The XS series offers an integrated environment for routing and switching HDMI and analog sources and digital displays. The series enables high-speed switching for HDMI, RGB, component, S-video, and composite video, as well as routing for up to four outputs.
- The series features EDID emulation for HDMI and RGB signals, managing EDID information between the display and HDMI source to ensure a stable system environment for HDMI.
- The HDCP key master feature maintains authentication information for each HDMI source enabling high speed switching under 5 frames.
- The powerful DSP enables the switching and mixing of audio input as well. Up to four audio mixes can be created from both analog audio inputs as well as embedded HDMI audio inputs. The resultant mix can be embedded back into the HDMI/HDBaseT output as well as analog audio outputs.

High-quality Video Processing

- The XS series has up to four internal scalers provided with compositing functions (*). It can scale individual inputs of HDMI, RGB, component, S-video, or composite video and output the results in a format suited to the system. Scaling can be adjusted in single-pixel increments enabling display of video that fits any screen exactly.
*When compositing functions, all outputs are fixed to the same format.
- Resolutions up to WUXGA/1080p are supported for both input and output. Deinterlacing interlaced video for output as a progressive signal is also possible.
- Video signals can be flipped vertically and horizontally, or rotated 90 degrees. Using this in combination with scaling makes split-picture output possible.
- The Preview Out function enables the user to check a video source before sending it to an output. The Presentation mode enables the operator to view guides lines indicating the main screen output size.

Integrated Video and Audio Environment

- The XS series achieves sophisticated sound processing thanks to the built-in audio DSP technology from Roland. Along with eight HDMI audio inputs, the series can accept eight stereo analog audio inputs as well. For audio-level adjustment, in addition to using the unit's knob, detailed settings can be configured by remote control from an iPad or external controller. Monitoring volume levels is convenient with the level meter display on each output.
- The XS series accommodates mic-level audio input on two channels. A built-in ducking function enables lowering the volume of other audio during microphone input.
- The audio inputs are each provided with an internal high-pass filter, 4-band equalizer, noise gate/expander, and compressor.
- The audio outputs are each provided with a 4-band equalizer, noise gate/compressor, and delay.

Integrated Video and Audio Environment

- Using the Roland WNA1100-RL wireless USB adapter enables direct control from an Apple iPad installed with Roland XS Remote. Along with operating the unit, Roland XS Remote can be used to change settings instantly with its memory-recall function.

- ### Controllable functions
- Preset change
 - Video switching
 - Audio level control
 - Change of Mode



Roland WNA1100-RL
*sold separately.



XS Remote

Application Examples

Conference Rooms

The XS series can perform switching for up to eight computers and video devices. Systems comprising mixed digital and analog video sources in HDMI, RGB, Component, S-video, and composite can be configured. For audio as well, up to eight stereo channels of input can be switched and mixed. The ducking function also makes it possible to lower audio-line volume when someone speaks into a microphone. Performing output using HDBaseT enables transmission of 1080p high-definition video over Cat5e cable to HDBaseT-compatible equipment up to 100 meters away.

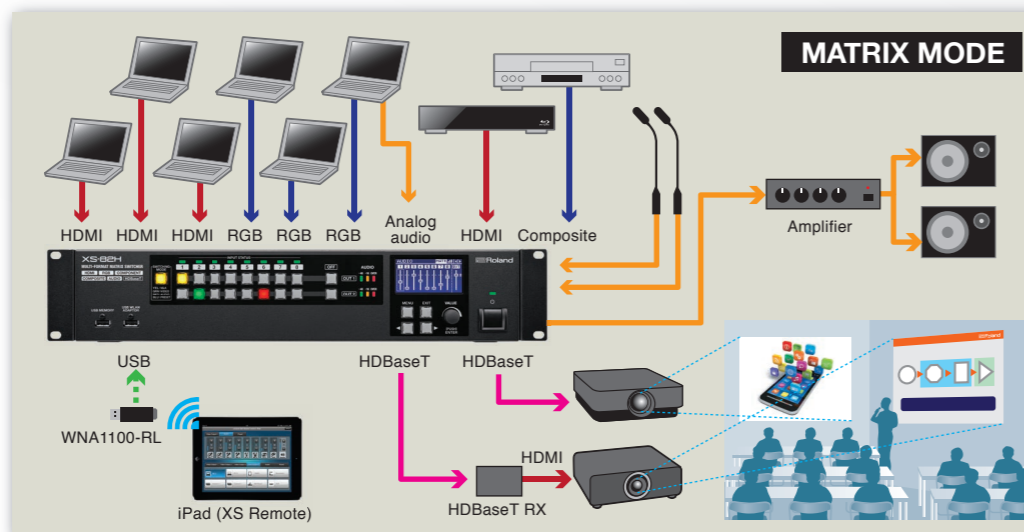

A variety of applications for any event and installation

4K Mode

The XS-84 is capable of switching four video lines as a group, enabling configuration of a 4K system. Switching a mixture of video feeds that includes 4K, HD, and SD sizes as well as up to WUXGA and other computer video formats is also possible.

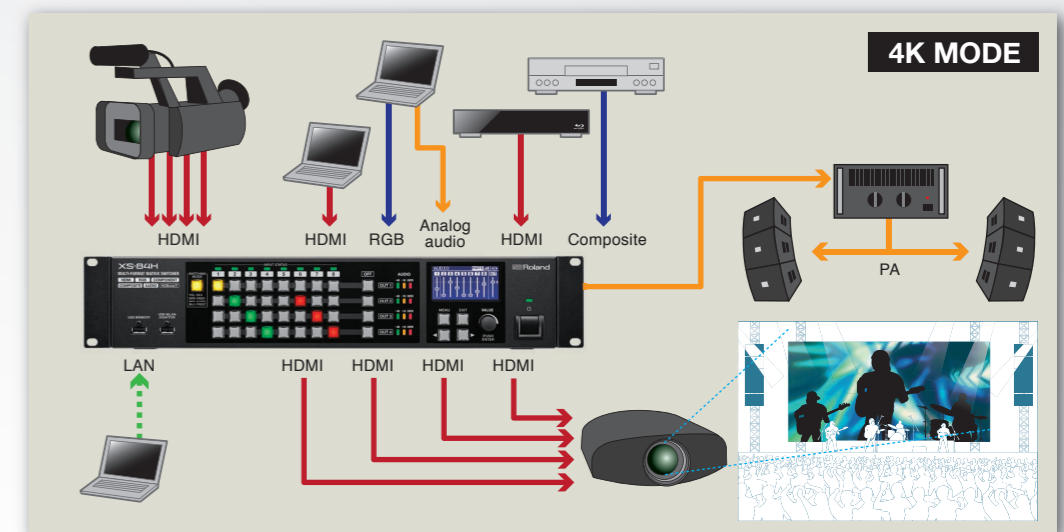

Classrooms

The XS series can switch between HDCP-protected HDMI video from computers and smart phones and still-image data saved in internal memory. It can also display a school emblem while in standby with no equipment connected. Built-in compressors, EQs, and HPFs on the input lines enable adjustment of mic and line audio. Output on up to four HDBaseT lines makes it possible to transmit video to sub-displays.

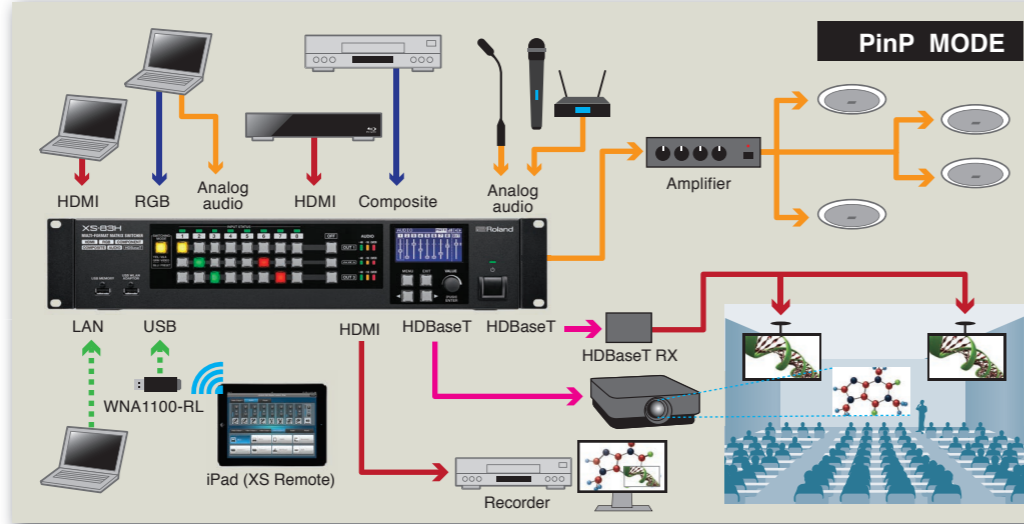

Teleconferencing Solutions

The XS series features four internal buses each for video and audio. It can be used to create minus-one audio, enabling incorporation into teleconferencing systems.

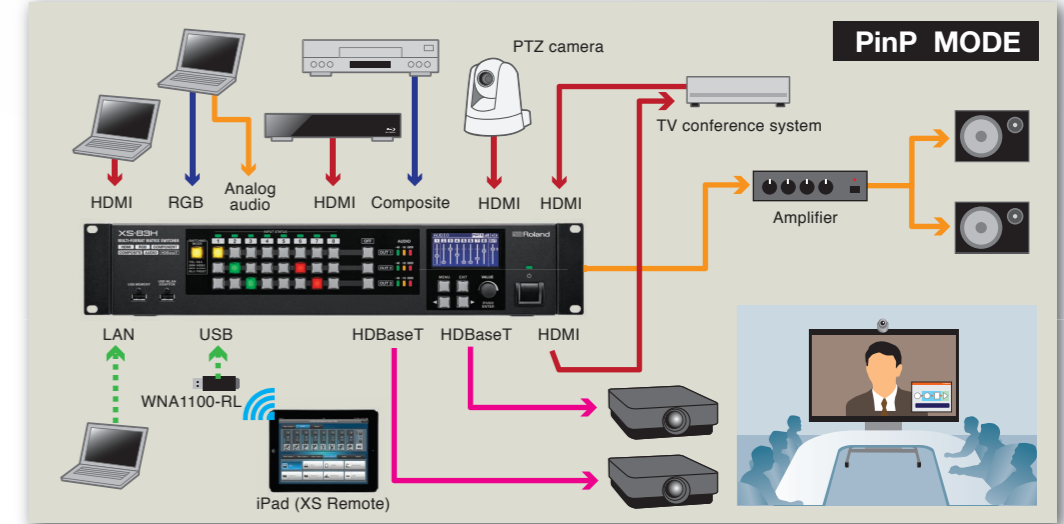

Event Halls and Churches

The XS series supports component, S-video, and composite feeds in addition to HDMI and RGB, making it ideal for event halls equipped with sources in various media formats. Multi-screen productions become possible with the different video modes. The horizontal mirroring and cropping functions enable the creation of laterally symmetrical video output while still sending a wide shot to the lobby.

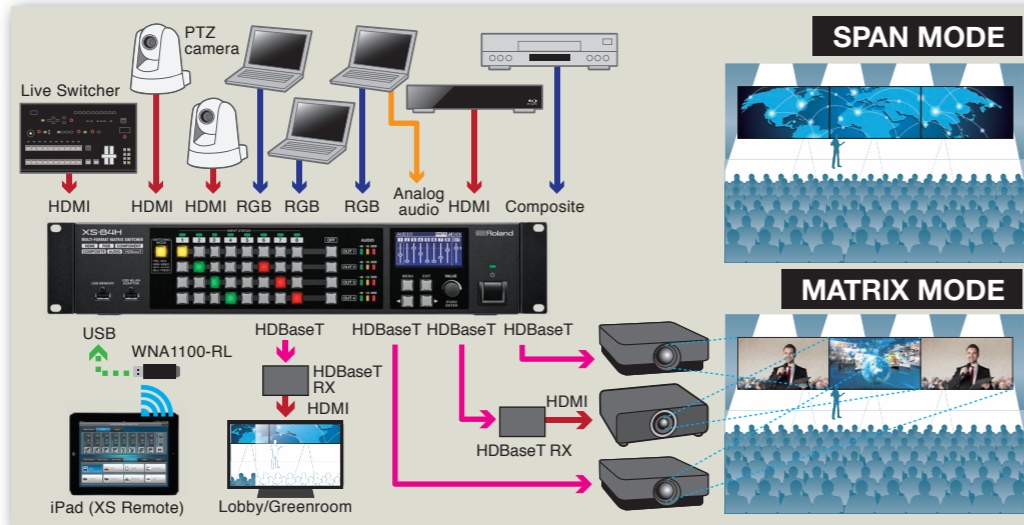

Events and Conventions

The XS series is equipped with eight ports each for HDMI and RGB/Component/S-video/Composite input, giving it enough capacity to accommodate even large conventions. Previewing output is possible as well, enabling adjustment of the positioning, scaling, and aspect of the input signal before output. The compositing functions make it possible to composite different types of informational screens separately from the main screen, for output to monitor displays visible to presenters and performers.

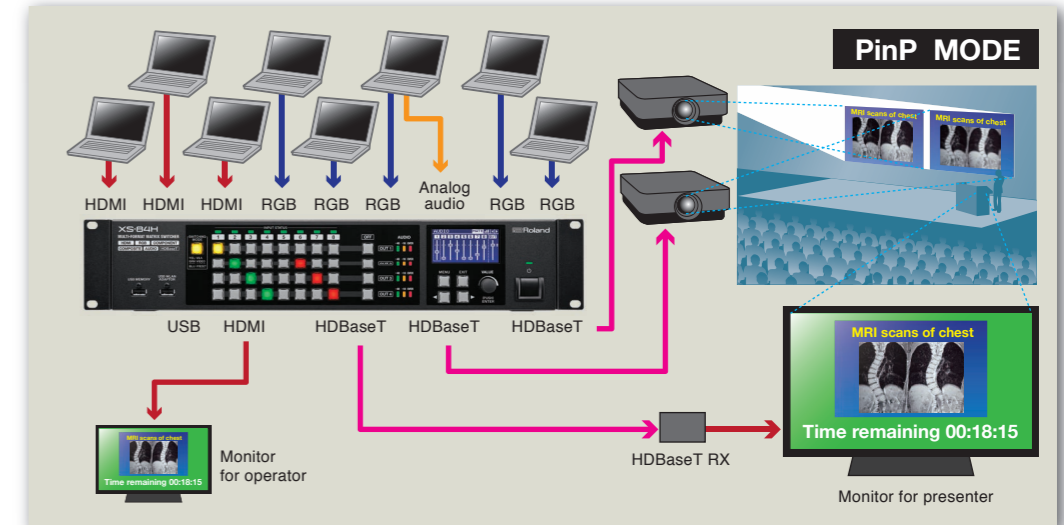

Panels and functions

XS-84H

Switching Mode

This selects whether the matrix switches just video, just audio, combined audio/video, or preset.

Input Signal LEDs

These provide a color-coded indication of the presence of an input signal, what type it is, and its HDCP status.

LCD Panel

An LCD screen features a backlit display for menu control and easy visibility in dark settings.

Front Panel



USB Memory Port

A USB flash drive can be inserted for backing up settings or importing still pictures.

USB Wireless LAN Adaptor Port

Connecting the wireless adapter, WNA-1100RL, enables direct control of the XS from an iPad.

Matrix Switches

These set the input channels as well as ON/OFF for each output.

Audio Level

These display the audio output level on each channel.

A superior, easy-to-use interface that achieves switching and distribution

LAN Port

Enables control over a network connection. Connect a wireless router and control with an iPad.

HDMI Audio

Embedding HDMI input into other outputs as well as de-embedding to analog audio outputs. Internal delay settings enable alignment of audio to video for perfect lip-sync.

8 Stereo Audio Inputs

The unit has eight stereo audio inputs that support line levels. Support for audio follow enables audio switching coordinated with video switching.

2 Mic Inputs compatible with 48V phantom
Two audio inputs with support for mic levels and phantom power are provided. An internal ducking function enables the ability to have the mic level automatically mixed above any other audio input.

Rear Panel

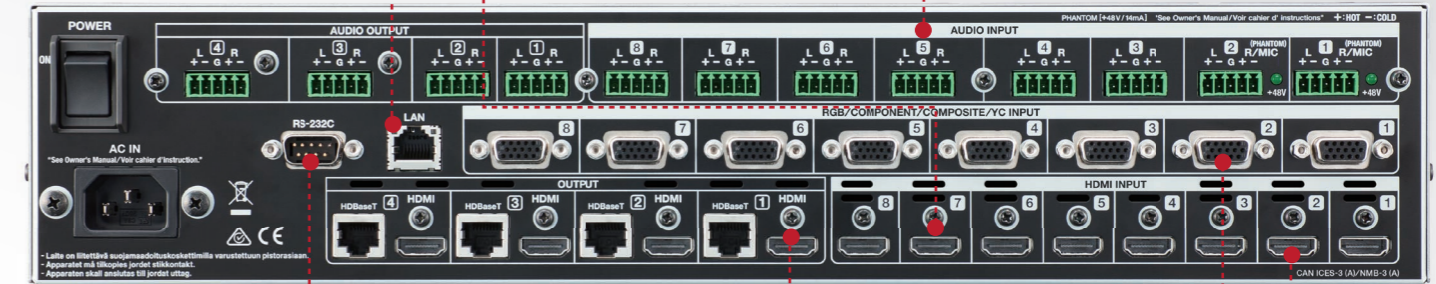

RS-232C Port

Serial connection enables control by external devices such as wall panels, remote buttons, etc.

HDMI/HDBaseT Outputs

Resolutions up to WUXGA/1080p are supported. Each output block provides an HDBaseT connector for transmitting digital signals via Cat5e/6 cable over distances of up to 100 meters.
*Switchable HDMI or HDBaseT per outputs
*HDBaseT device or receiver necessary at the receiving end.

HDMI/RGB Inputs

Resolutions up to WUXGA/1080p are supported. A built-in EDID emulator copies the EDID info of the display receiving output, achieving input and output of highest quality.

Video Processing

Output Mode

The XS series has four preset output modes that can be edited.

MATRIX MODE



SPAN MODE



P in P MODE



4K MODE



Block Diagram

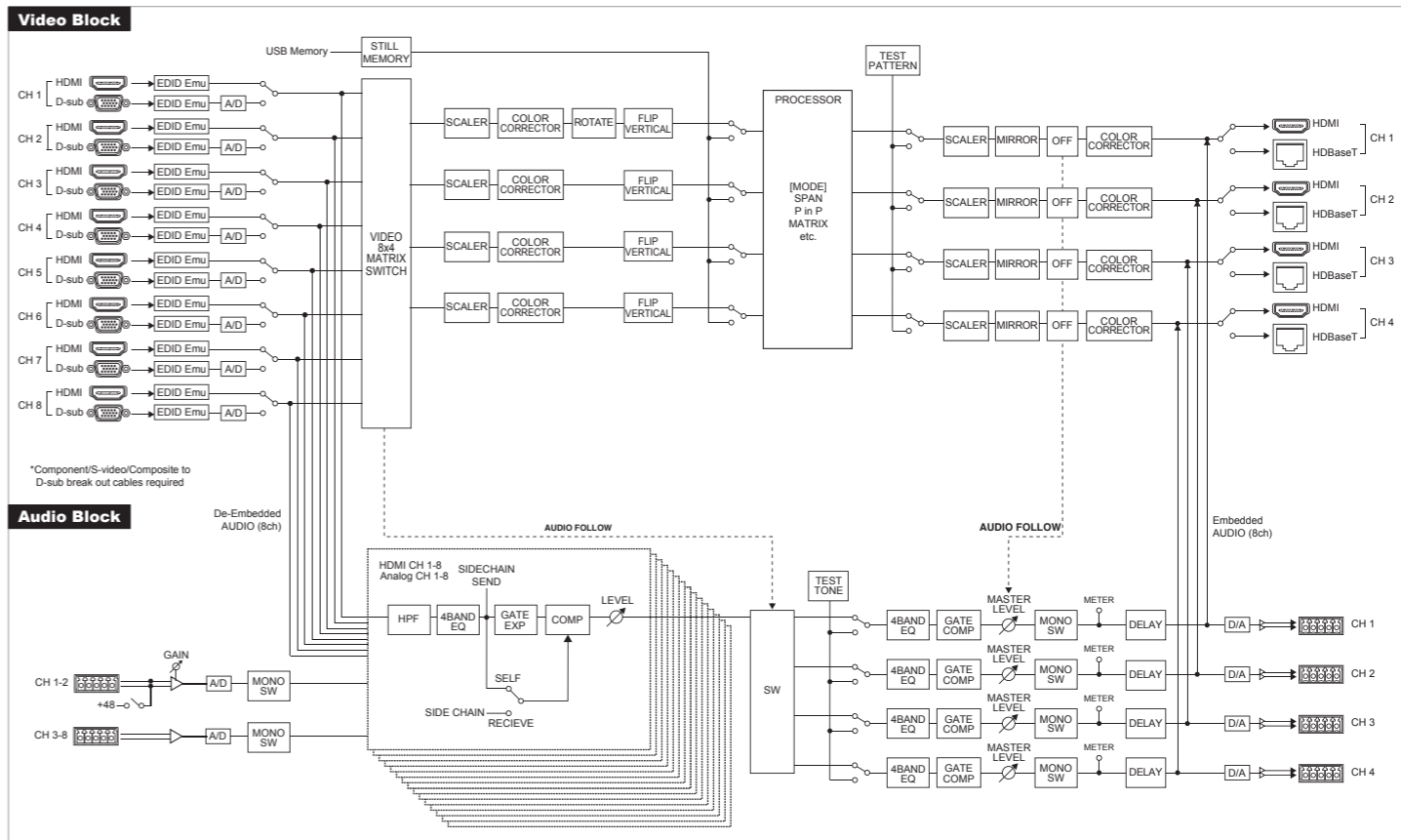

Specifications

■ Video			■ Audio Processing		
Processing	4:4:4 (Y/Pb/Pr), 10-bit		Audio Processing	Sampling Rate : 24-bit/48 kHz	
Input Connectors	HDMI : Type A (19 pin) x 8 (Input 1 to 8) *HDCP supported RGB/Component/S-video/Composite : HD DB-15 type x 8 (Input 1 to 8)		Input Connectors	Digital : HDMI Type A (19 pin) x 8 Analog : 5 pin terminal block connector x 8	
Output Connectors	XS-82H	HDMI : Type A (19 pin) x 2 (Output 1 to 2) HDBaseT : RJ-45 x 2 (Output 1 to 2) *HDCP supported	Output Connectors	XS-82H	Digital : HDMI Type A (19 pin) x 2 Analog : 5 pin terminal block connector x 2
	XS-83H	HDMI : Type A (19 pin) x 3 (Output 1 to 3) HDBaseT : RJ-45 x 3 (Output 1 to 3) *HDCP supported		XS-83H	Digital : HDMI Type A (19 pin) x 3 Analog : 5 pin terminal block connector x 3
	XS-84H	HDMI : Type A (19 pin) x 4 (Output 1 to 4) HDBaseT : RJ-45 x 4 (Output 1 to 4) *HDCP supported		XS-84H	Digital : HDMI Type A (19 pin) x 4 Analog : 5 pin terminal block connector x 4
Input/Output Level and Impedance	RGB/Component	Level : 1.0Vp-p (luminance), 0.286Vp-p (chroma, NTSC), 0.3Vp-p (chroma, PAL) Impedance : 75 ohms	Output Level and Impedance	Ch 1 to 4 : +4dBu (Maximum: +22 dBu), 600 ohms	
	Composite /S-video	Level : 1.0Vp-p (luminance), 0.286Vp-p (chroma, NTSC), 0.3Vp-p (chroma, PAL) Impedance : 75 ohms	Audio Formats	HDMI : Linear PCM, 24bit, 48kHz, 8ch	
Input Supported Formats	HDMI	up to 1080p/59.94, up to 1920x1200/60	Audio Effects	Input : High-pass filter, 4-band equalizer, Gate/Expander, Compressor Output : 4-band equalizer, Gate/Compressor, Delay	
	Component	up to 1080p/59.94		■ Others connectors RS-232C : D-Sub 9 pin type x 1 LAN : RJ-45 x 1 USB : A Type x 2 for USB memory, for WNA-1100RL	
Output Supported Formats	RGB	up to 1920x1200/60 *Reduced Blanking	■ Display		
	Composite	480i/59.94, 576i/50	2 color LCD 128 x 64 dots		
Effects	S-video	480i/59.94, 576i/50	■ Others		
	Still Image:	Windows® Bitmap File (.bmp) * Maximum 1920 x 1200 pixels, 24 bit per pixel, uncompressed	Power Supply : AC 115 V, AC 117 V, AC 220 V, AC 230 V, AC 240 V (50/60 Hz) Power Consumption : 50w Dimensions : 481(W) x 334(D) x 88(H), EIA-2U Rack mountable size Weight : 5.3kg Accessories : Power Cord, Captive Screw Connectors, Rubber Feet, Owner's Manual		

* 0dBu = 0.775Vrms

Options

Conversion of video and audio signals from HDMI input to SDI output



VC-1-SH
SDI to HDMI

Conversion of video and audio signals from HDMI input to SDI output



VC-1-DL
FS Delay

Conversion of video and audio signals from HDMI input to SDI output



VC-1-HS
HDMI to SDI

Conversion of video and audio signals from HDMI input to SDI output



VC-1-SC
Scan Converter

Dimensions

Unit: mm

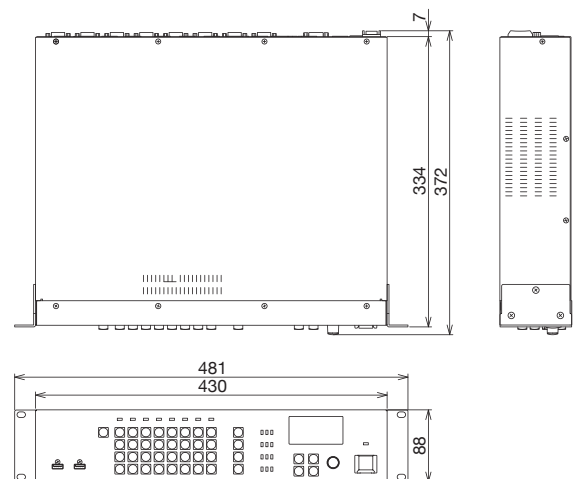

Roland
Systems Group

Roland Systems Group, a member of the worldwide group of Roland companies, is dedicated to the support of audio and video professionals demanding excellence in both performance and system design. Through the development and support of video and audio products, we endeavor to improve workflow and maximize creative possibilities.

Roland

All specifications and appearances are subject to change without notice. Company names and product names appearing in this document are registered trademarks or trademarks of their respective owners. Roland is either registered trademark or trademark of Roland Corporation in the United States and/or other countries. iPad is a trademark of Apple Inc. It is forbidden by law to make an audio recording, video recording, copy or revision of a third party's copyrighted work (musical work, video work, broadcast, live performance, or other work), whether in whole or in part, and distribute, sell, lease, perform, or broadcast it without the permission of the copyright owner. Do not use this product for purposes that could infringe on a copyright held by a third party. We assume no responsibility whatsoever with regard to any infringements of third-party copyrights arising through your use of this product. Copyright 2014 Roland Corporation. All rights reserved.